

HC-49SMD Series Crystal Resonator

Features:

- .Low cost
- .Industry standard package
- .High reliability and stability crystal
- .Wide frequency range and calibration tolerances
- .Available
- .Rohs compliant / Pb free



Specification:

Model	HC-49SMD
Frequency Range	3.570 ~ 100.000MHz
Frequency Tolerance at 25°C±2°C	±20 ~ ±50ppm(TYP.)
Frequency Stability Over Operating Temp Range	±10 ~ ±50ppm(TYP.)
Operating Temp Range	-10°C ~+60°C, -20°C ~+70°C, -40°C ~+85°C or customer requirement
Load Capacitance	8pF ~32pf,series or special
Shunt Capacitance	7pf Max
Drivel Level	0.1uW~1000Uw(TYP:100uw)
Insulation Resistance	500MΩ min / DC 100V±15V
Oscillation Mode	Fundamental,3 rd & 5 th overtone
Measure Instrument	S&A 250B

Equivalent Series Resistance(ESR)VS Frequency:

Frequency(MHz)	Oscillation Mode	HC-49SMD
3.57 ~ 3.79	Fundamental	180Ω max
3.8 ~ 4.49	Fundamental	150Ω
4.5 ~ 5.99	Fundamental	120Ω
6.0 ~ 7.99	Fundamental	100Ω
8.0 ~ 9.99	Fundamental	80Ω
10.0 ~ 11.99	Fundamental	70Ω
12.0 ~ 15.99	Fundamental	60Ω
16.0 ~ 19.99	Fundamental	50Ω
20.0 ~ 39.99	Fundamental	40Ω
26.0 ~ 39.99	3 rd overtone	100Ω
40.0 ~ 70.0	3 rd overtone	80Ω
70.0 ~ 100.0	3 rd overtone	100Ω

Dimensions: 49SMD

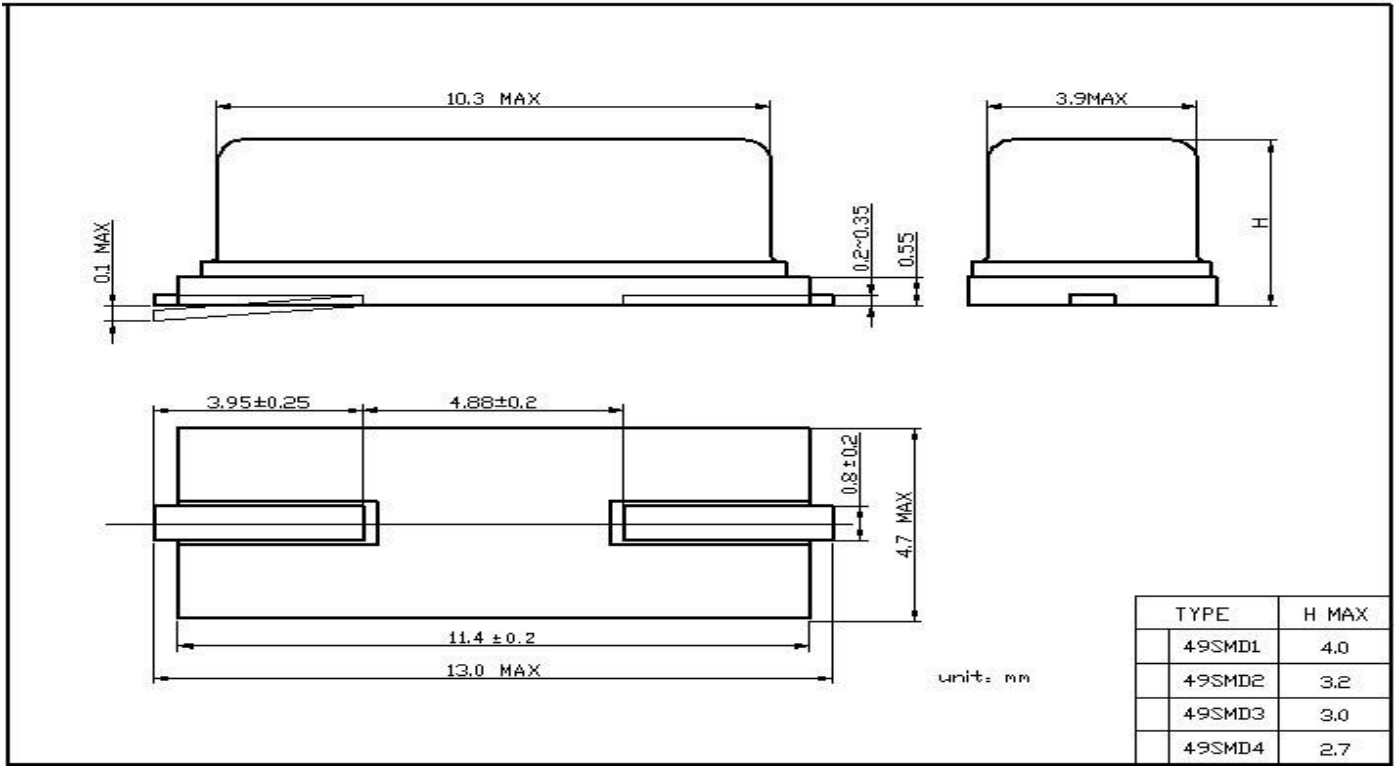

49SSMD

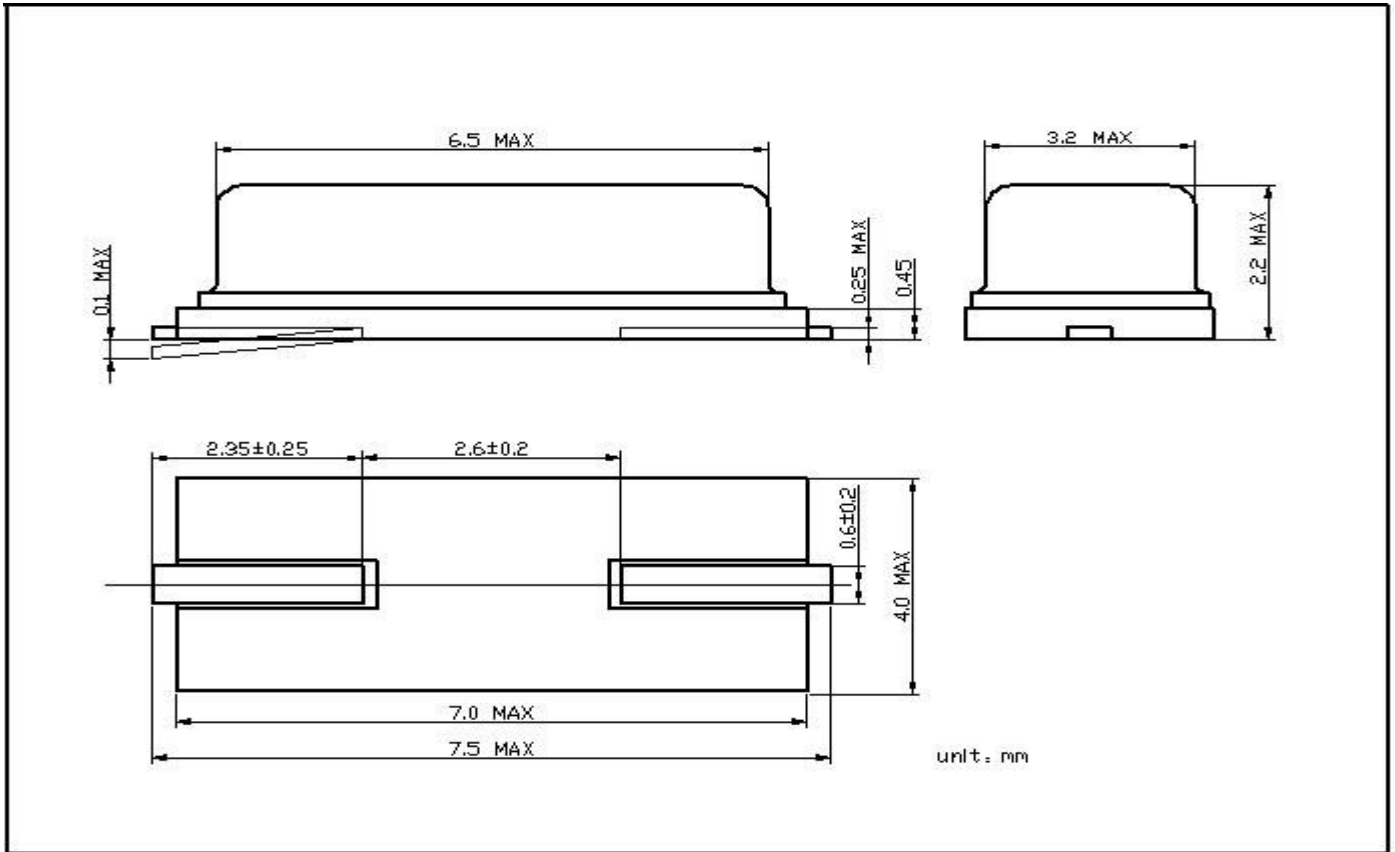

* Above specification subject to change without prior notice, please consult our sales @ www.crystal-bj.com